

# LIBERATOR 6000



Available with Wireless Remote Control!



Designed to a Higher Standard

Ideal Crane LLC is committed to designing and manufacturing the best electric hydraulic crane value in the industry. Our cranes are innovatively designed to perform to a higher standard of durability and reliability, and to provide the maximum duty cycle possible in an electric crane. For nearly 50 years we've backed that commitment with our limited lifetime structural warranty and factory direct technical support. You can be assured that your new Ideal Liberator crane will provide many years of dependable service.

- ◆ Solid-state controls with Arc-Suppression circuits to extend life for switches and contactors.
- ◆ Large diameter swing bearing has stronger all-steel worm gear for positive "hillside" load locking.
- ◆ Exclusive "POWER ARM" feature produces the most power efficient booming in the industry.
- ◆ "eXtended On Time" hydraulic system increases duty cycle and prevents costly breakdowns.
- ◆ Meets OSHA 1910.180 and ANSI B30.5 specifications

[www.idealcrane.com](http://www.idealcrane.com)

IDEAL CRANE LLC - PO BOX 35249 - TULSA, OKLAHOMA 74153-0249

# LIBERATOR 6000

- 6000 lbs. Maximum Capacity
- 36,000 ft-lbs Crane Rating

## SPECIFICATIONS

Liberator 6000 cranes come complete with 25' power cable, all wiring harnesses required to hook up, and a 225 amp fuse. A 25' remote control pendant, mounting bolts and owner's manual are also included. All Liberator 6000 cranes are shipped assembled, factory tested and ready to go to work.

2 ea. 1000 amp CCA batteries are required. A 150 amp alternator is recommended. 14,500 GVW chassis recommended minimum.

### ► Maximum Lifting Capacities ◀

6000 Lbs.	@ 6 ft.	2571 Lbs.	@ 14 ft.
5143 Lbs.	@ 7 ft.	2250 Lbs.	@ 16 ft.
4500 Lbs.	@ 8 ft.	2000 Lbs.	@ 18 ft.
3600 Lbs.	@ 10ft.	1800 Lbs.	@ 20 ft.
3000 Lbs.	@ 12ft.	1636 Lbs.	@ 22 ft.

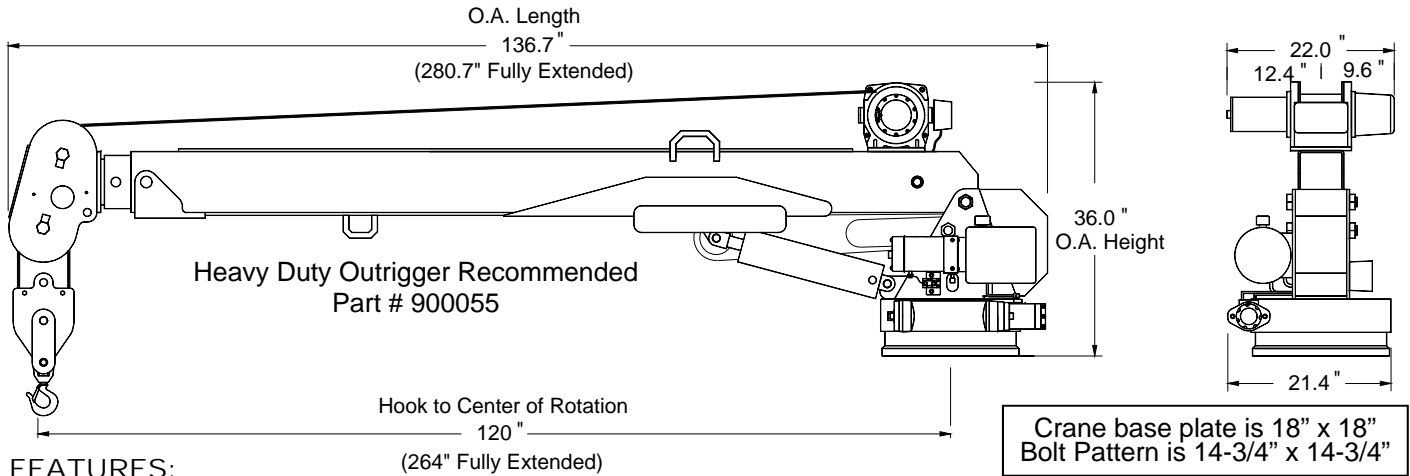

#### FEATURES:

- Self-contained 24 Volt DC hydraulic system supplies 2.2 gallons per min, powered by high-output extended on time series wound motor.
- Automatic overload protection prevents hoist up, boom extension and boom down.
- Anti two-block system is standard on all cranes with power extension.
- Large diameter, self-locking, all steel worm gear rotation drive is mounted on steel slewing ring crane bearing and provides 380 degree power rotation.
- Load cushioning counterbalance/check valves on all cylinders for precise load holding and handling.
- Safety valves on all cylinders prevents load drop if hose fails.
- 100% Solid-state control system has arc-suppression circuitry for extended life of switches, contactors and motors. No mechanical control relays used.
- Powder coat finish for high gloss and durability.
- Hydraulic boom elevates using exclusive **Power Arm** technology from  $-5^{\circ}$  to  $+75^{\circ}$ .
- 25' non-metallic, remote control with "Quik-Turn" quick disconnect.
- Planetary gear hoist is designed for maximum power, efficiency and hook speed.
- Industrial grade electrical contactors, no automotive type solenoids.
- 100ft of 3/8" wire rope. Hoist drum and wire rope are on the outside of the boom where they are visible to the operator.
- Polymer wire rope pulleys reduce wire rope wear and are permanently lubricated.
- Boom extensions slide on low friction self-lubricating polymer slide pads.
- Meets OSHA 1910.180 requirements, and ANSI B30.5 safety standards .
- Mounting bolts provided (4 ea. 1" grade 8).

Model	Power Boom	Power Extend	Manual Extend	Weight	O.A. Lgth Retracted	O.A. Width
LIB 6000 PXTW16	Yes	10' to 16'	none	1450#	11' 6"	22"
LIB 6000 PXTW22	Yes	10' to 16'	16' to 22'	1550#	11' 8"	22"
LIB 6000 LS	Yes	10' to 22'	none	1600#	11' 8"	22"



PO Box 35249 - Tulsa, Oklahoma 74153-0249  
**(800) 622-6163** fax **(918) 234-0564**  
[www.idealcrane.com](http://www.idealcrane.com)

Distributed by:

