

LIBERATOR 5000

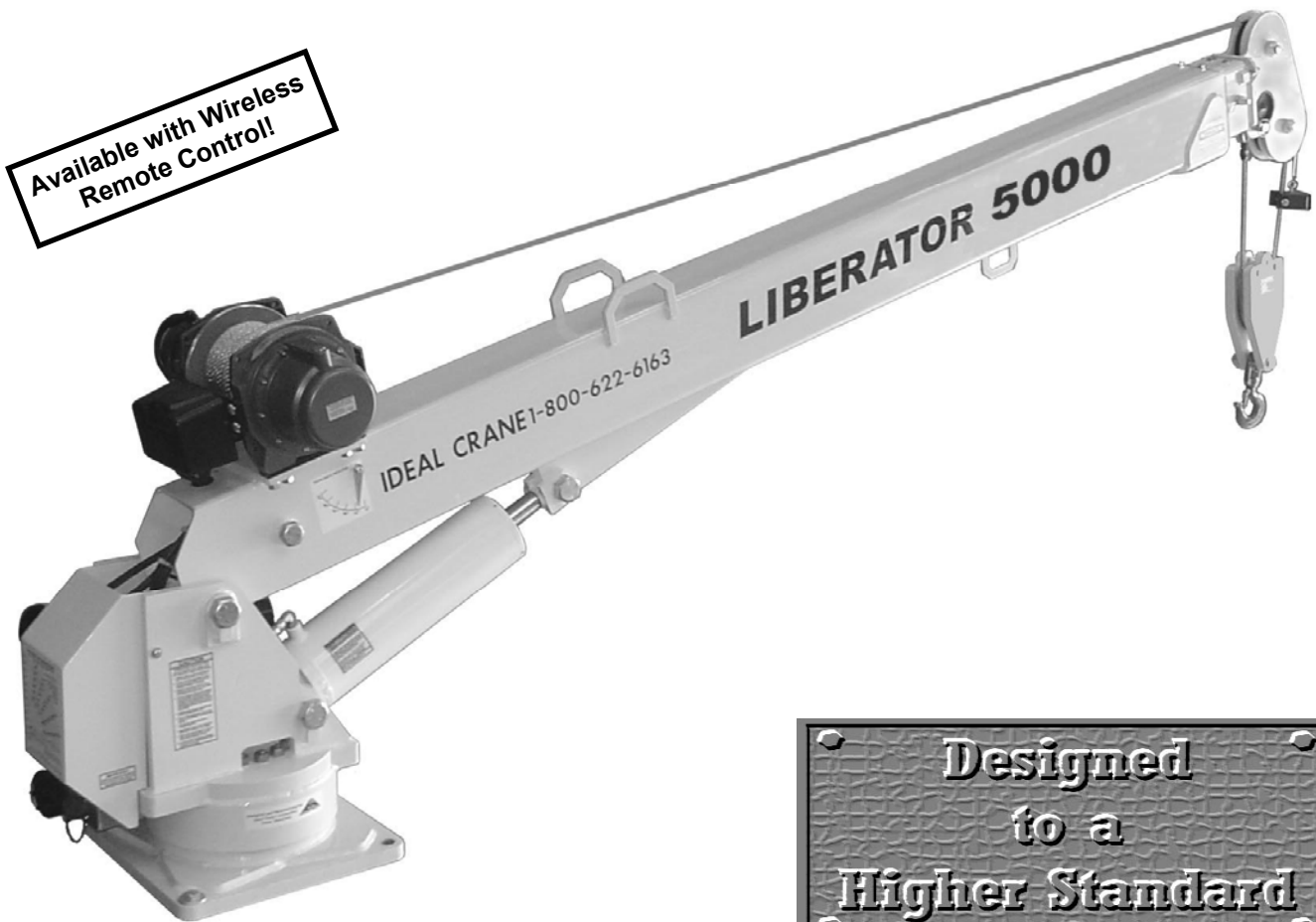

Ideal Crane L.L.C. is committed to designing and manufacturing the best electric hydraulic crane value in the industry. Our cranes are innovatively designed to perform to a higher standard of durability and reliability, and to provide the maximum duty cycle possible in an electric crane. For nearly 50 years we've backed that commitment with our limited lifetime structural warranty and factory direct technical support. You can be assured that your new Ideal Liberator crane will provide many years of dependable service.



5,000 lb. Max Capacity - 25,000 ft-lb Moment Rating

- ◆ Solid-state controls with Arc-Suppression circuits to extend life for switches and contactors.
- ◆ Large diameter swing bearing has stronger all-steel worm gear for positive "hillside" load locking.
- ◆ "eXtended On Time" hydraulic system increases duty cycle and prevents costly breakdowns.
- ◆ Meets OSHA 1910.180 and ANSI B30.5 specifications.

www.idealcrane.com

IDEAL CRANE L.L.C. - PO BOX 35249 - TULSA, OKLAHOMA 74153-0249

LIBERATOR 5000

- 5,000 lbs. Maximum Capacity
- 25,000 ft-lbs Crane Rating

SPECIFICATIONS

Liberator 5000 cranes come complete with 25' power cable, all wiring harnesses required to hook up including a 225 fuse. A 25' remote control pendant, mounting bolts and owner's manual are also included.

All Liberator 5000 cranes are shipped assembled, factory tested and ready to go to work. Minimum chassis size, 10,500 GVW. 1000 amp CCA, deep cycle battery is required. A 150 amp alternator is recommended.

► Maximum Lifting Capacities ◀

5000 Lbs. @ 5 ft.	2083 Lbs. @ 12 ft.
4166 Lbs. @ 6 ft.	1785 Lbs. @ 14 ft.
3571 Lbs. @ 7 ft.	1562 Lbs. @ 16 ft.
3125 Lbs. @ 8 ft.	1388 Lbs. @ 18 ft.
2500 Lbs. @ 10 ft.	1250 Lbs. @ 20 ft.

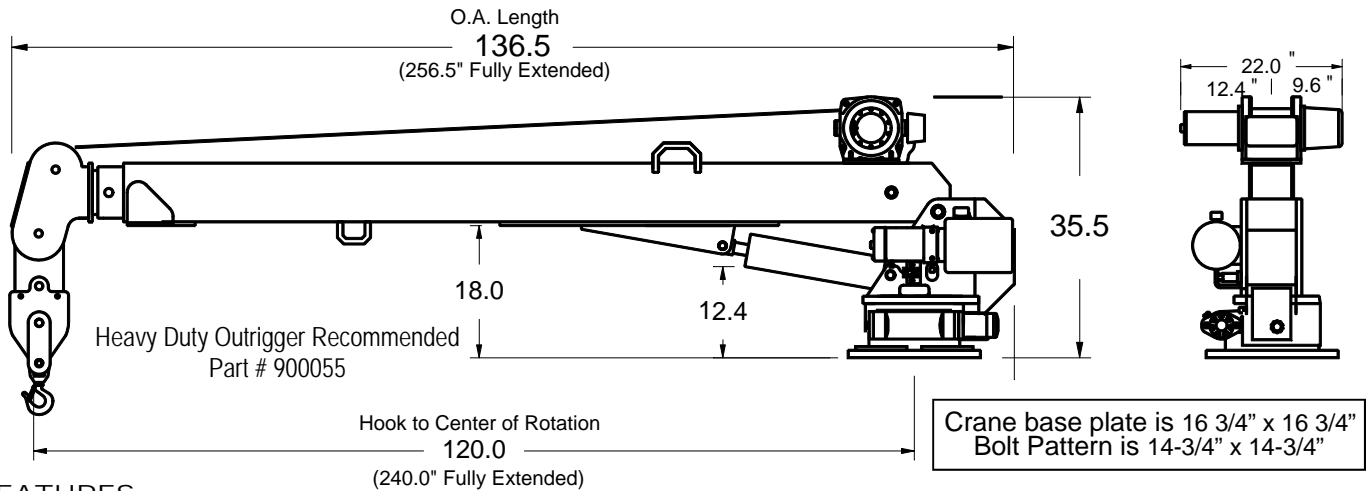

FEATURES:

- Self-contained 12 Volt DC hydraulic system supplies 2.2 gallons per min, powered by high-output extended on time series wound motor.
- Automatic overload protection prevents hoist up, boom extension and boom down.
- Anti two-block system is standard on all cranes.
- Large diameter, self-locking, all steel worm gear rotation drive is mounted on steel slewing ring crane bearing and provides 360 degree continuous power rotation.
- Load cushioning counterbalance/check valves on all cylinders for precise load holding and handling.
- Safety valves on all cylinders prevents load drop if hose fails.
- Proprietary, 100% Solid-state control system has arc-suppression circuitry for extended life of switches, contactors and motors.
- 5,000 lb. max. capacity, 25,000 ft-lb moment rating.
- Hydraulic boom elevation from -5° to 75°.
- 25' remote control with "Quik-Turn" quick disconnect with non-metallic switch box.
- Planetary gear hoist is designed for maximum power, efficiency and hook speed.
- Industrial grade electrical contactors, no automotive type solenoids.
- 85' of 5/16" wire rope. Hoist drum and wire rope are on the outside of the boom where they are visible to the operator.
- Polymer wire rope pulleys are permanently lubricated to extend life and reduce wire rope wear.
- Boom extensions slide on low friction self-lubricating polymer slide pads.
- Meets OSHA 1910.180 requirements. and ANSI B30.5 safety standards .

Model	Power Boom	Power Extend	Manual Extend	Weight	O.A. Lgth Retracted	O.A. Width
LIB 5000 PXTW-PR	Yes	10' to 16'	none	1300#	11' 2-1/2"	22"
LIB 5000 PXTW20-PR	Yes	10' to 16'	16' to 20'	1400#	11' 4-1/2"	22"
LIB 5000 LS	Yes	10' to 22'	none	1450#	11' 4-1/2"	22"



... better by design ...

PO BOX 35249 - TULSA, OKLAHOMA 74153-0249
 (800) 622-6163 fax (918) 234-0564
 www.idealcrane.com

Distributed by: